

REVISIONS					
REV.	DATE	ECN#	DESCRIPTION	BY	APPROVED
1	6/12/2015	PQI# 11864	14.50 WAS 14.94, 2.94 WAS 2.50, REMOVED CORONA CAP NAMEPLATE	CLS	

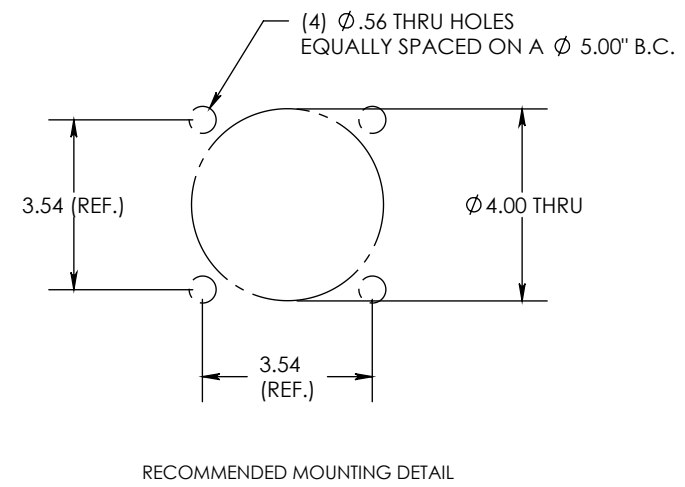

- NOTES:  
 1. ALL CONTACT SURFACES TO BE CLEAN & FREE FROM FLASH
- MATERIAL:  
 1. CYCLOALIPHATIC EPOXY (U.V. EXPOSED), COLOR: GREY  
 2. C110 GRADE COPPER
- SPECIFICATIONS:  
 1. MANUFACTURED IN ACCORDANCE WITH .... IEC 137-1995, CAN/CSA-C88.1-96, IEEE C57.19.01-1991  
 2. RATED VOLTAGE ..... 25kV  
 3. POWER FREQUENCY WITHSTAND ..... 60kV  
 4. BASIC IMPULSE LEVEL ..... 150kV  
 5. NOMINAL CURRENT RATING ..... 2000 AMPS  
 6. CREEP DISTANCE ..... 33"/838 mm (24 mm/kV)  
 7. TEMPERATURE CLASSIFICATION..... -50°C TO +105°C

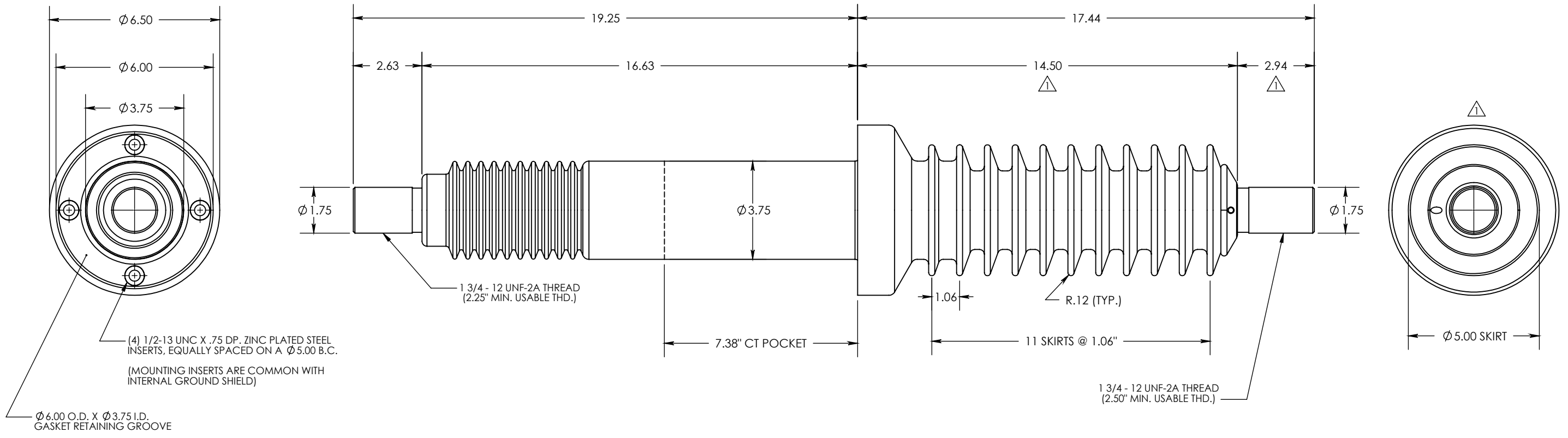

**H-J INTERNATIONAL, INC.**  
 3010 HIGH RIDGE BLVD, HIGH RIDGE, MO. 63049 USA  
 PHONE 1-636-677-3421 FAX 1-636-376-1915

**POWER APPARATUS BUSHING**  
**25kV / 2000A**

**PROPRIETARY AND CONFIDENTIAL**  
 THE INFORMATION CONTAINED IN THIS DRAWING IS THE SOLE PROPERTY OF H-J INTERNATIONAL, INC. ANY REPRODUCTION IN PART OR AS A WHOLE WITHOUT THE WRITTEN PERMISSION OF H-J INTERNATIONAL, INC. IS STRICTLY PROHIBITED.  
 BREAK ALL SHARPS UNLESS OTHERWISE NOTED

TOLERANCES (EXCEPT AS NOTED)	
ONE PLACE MM	$\pm 1.50$
TWO PLACE MM	$\pm 0.75$
TWO PLACE DEC.	$\pm .060$
THREE PLACE DEC.	$\pm .030$
FRACTIONS	$\pm 1/16"$
ANGLES	2°

APPROVED BY	NJS	DATE	06/12/2015
CHECKED BY	NJS	DATE	06/12/2015
DRAWN BY	DB	DATE	05/17/2001
TOOL NO.	T20-450-1		
PRODUCT GRP.	2000 SERIES		

DRAWING NO. <b>20-450-100</b>			
SCALE	1:4	SIZE	B
REV.	1	SHEET	1 OF 1